

Installation Guidelines and Homeowner Warranty

(Waiver Opt-Out Information Enclosed)

FOR PINNACLE MULTI-SLIDE PATIO DOORS

Installer

- Read instructions completely before attempting installation. Failure to follow these guidelines will forfeit all warranties (written or implied). Windsor Windows & Doors will not be held responsible for any claims or damages resulting from installation.
- Always provide a copy of these instructions to the homeowner.
- Contact your architect or construction professional for installation into other building designs or construction methods.
- Structural support of the sill is required to support the entire sill width, and depth of the sill's interior edge, to the exterior nose of the sill extrusion. If the architect's details do not include this type of structural support, a structural support must be installed and flashed.
- Regional codes and environmental conditions may require installation that is different from these guidelines. It is your responsibility to ensure that local codes and ordinances are followed.

Warning!

- ⚠ **Work Safe!** Always wear proper eye and hearing protection when installing or adjusting Windsor products.
- ⚠ **Use Power Tools Properly!** To avoid personal injury, always follow manufacturers' instructions for safe operation of power tools.
- ⚠ **Ladder Safety!** Working at elevated levels can be hazardous. Always use ladders and scaffolding properly. Consult manufacturers' guidelines for safe use of these types of equipment.

Important

- Windsor reserves the right to change the information contained in these guidelines without notice.
- Maintain a minimum of 1/4" between the door frame and any trim, siding or masonry.
- Use of Windsor products in barrier EIFS systems (synthetic stucco) is not recommended. To do so will forfeit all warranties (written or implied). Windsor Windows & Doors will not be held responsible for any claims or damages resulting from water infiltration.
- Steel fasteners will corrode when used with ACQ pressure treated lumber. Use corrosion resistant fasteners (such as stainless steel) when installing windows in or around these types of materials.
- Door nailing flanges and drip caps (integral or applied) do not take the place of door flashing. All windows and doors must be properly flashed and sealed around the perimeter.

Handling and Storage

- Always carry door panels upright. Do not carry flat!
Doing so could result in damage to the panels.
- Do not store units outside.



www.windsorwindows.com

Tools Needed

- Safety Glasses
- Utility Knife
- Hammer (or nail gun)
- Caulk Gun
- Level
- Ladder / Scaffolding
- Square
- Tape Measure
- Drill / Screwdriver (#2 square bit)
- 7/16" Wrench

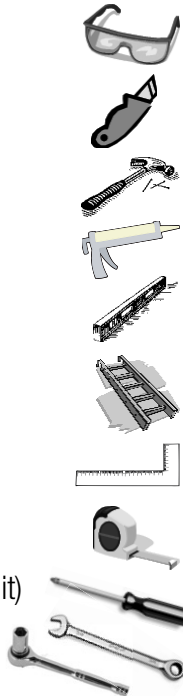

Materials Needed

- Insulation
 - Minimally expanding low pressure polyurethane window and door foam
- Shims
 - Made of cedar or synthetic material
- Coated Deck Screws
 - 1-1/2" x #8
- Sealant
 - 100% Silicone
- Flashing
 - Self-adhesive flexible flashing that complies with ASTM-D779
- White Petroleum Jelly (Vaseline®)
- Roofing Nails
 - 2" Galvanized (16D)
- **Sill Pan (Required)**

LEAD PAINT AND EXISTING WINDOW DISPOSAL:

- A) Before any remodel or renovation, make sure to identify any potential lead paint issues and take necessary steps to reduce the risk of lead contamination.
- B) The U.S. Environmental Protection Agency (EPA) has issued a "Lead Renovation, Repair and Painting Rule (RRP)" for remodelers of older homes and buildings. This rule requires training and certification in lead-safe work practices for firms performing renovation, repair or painting on homes and child-occupied facilities built prior to 1978.
- C) For more information regarding procedures for dealing with lead paint, please visit EPA's website at www.epa.gov/lead.
- D) When removing existing windows, make sure to wear appropriate personal protective equipment. Extra precautions should be taken to protect others and property within the vicinity and below the removal window and surrounding components.
- E) Consult with local waste authorities on the proper recycling or disposal of old window components.

ATTENTION! THIS DOCUMENT CONTAINS WAIVERS THAT AFFECT YOUR LEGAL RIGHTS. Please read the entire document carefully, especially the section entitled, “Dispute Resolution Process,” because that section contains statements reflecting your agreement to waive your rights to a jury trial and to participate in a class action case related to a dispute you have with Windsor arising out of the Windsor products covered by this warranty. **YOU CAN OPT OUT OF THESE WAIVERS. To do so, please go to www.windsorwindows.com/support and locate the Waiver Opt-Out Form. In order to opt out of these provisions, you must fill out the Waiver Opt-Out Form within one year of the date your Windsor products were manufactured, as indicated by the glass code on the product.**

Items Provided by Windsor Windows & Doors

- **Frame Parts**
 - Head jamb, side jambs and sill (to be assembled in field)
 - Post interlock (for pocket doors only)
- **Door Panels**
 - Lead panel (main locking panel)
 - Intermediate panels (quantity will depend on unit configuration ordered)
 - Pocket/stacking panel (will depend on unit configuration ordered)
- **Screw Packs**
 - Frame assembly
 - Nosing
 - Sill install
 - Head/side jamb
 - L-bracket
 - Post interlock (pocket doors only)
 - Follower (pocket doors only)
- **Frame Track Covers**
 - Head track covers (quantity will depend on unit configuration ordered)
 - Side jamb track covers (quantity will depend on unit configuration ordered)
- **Frame gaskets (head and sill)**
- **Handle set (applied to lead panel)**
- **Construction handle**
- **Collector plates**
- **L-brackets**
- **Aluminum panel follower (pocket door only)**
- **Wood pocket cover for aluminum panel follower (pocket door only)**
- **Foam corner seals for nail fin**
- **Frame nosing corner seals**
- **Nail fins – head, side, post interlock**

Step 1: Inspect Unit

Before Installation

- A) Remove all shipping packaging material (blocks, pads, protectors, stretch wrap).
- B) Inspect unit for any damage or defects.
- C) Check all parts received against the Packing List to ensure all required parts are present.
- D) Contact the nearest Windsor distributor if there is any problem.

Step 2: Opening Inspection

Verify Header Support

Confirm that the roof over the system is stacked and take into consideration the amount of weight of any materials at this location that may cause deflection of the header. No more than 1/8" deflection is allowable for proper system operation. The material/lumber quality and the fasteners must be structurally adequate for design load requirements. (Fig. 1)

Verify that the concrete or sub-floor of the rough opening is level. The frame system may be shimmed to compensate for an uneven floor, but this may adjust the relationship of the system sill to the finished floor and may increase the overall height of the system in the opening. Any serious deflection in the concrete or sub-floor where the system is to be installed must be corrected prior to installation. **Sill must be within 1/8" of level for every 10' of sill length.** (Fig. 2)

Assure that all opening measurements match those noted on the drawings that are provided with the system. (Fig. 3)

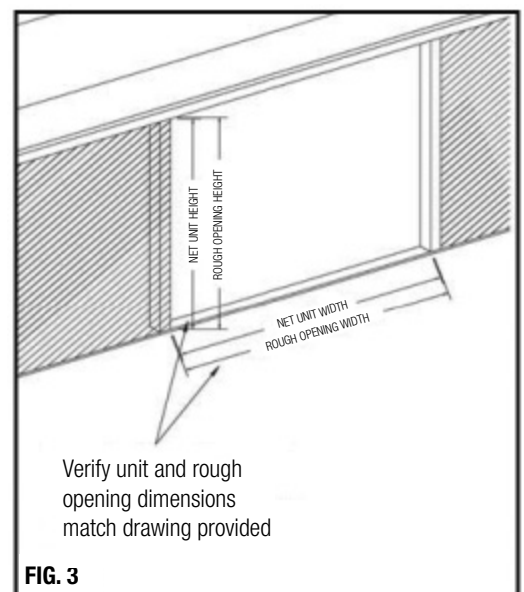
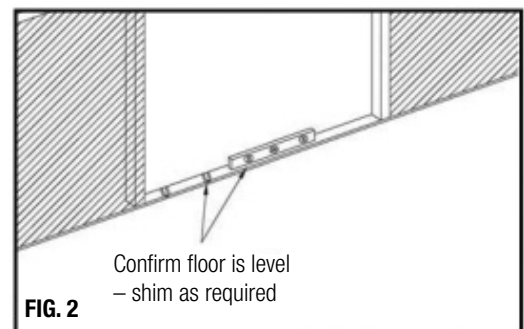
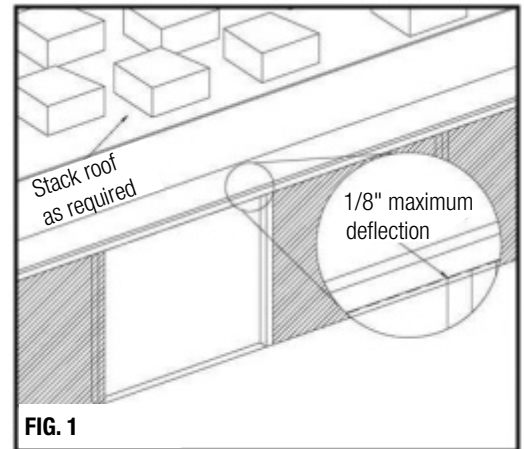

Prepare Rough Opening

- A) Measure and verify the size of the rough opening. The rough opening should be 1/2" larger than the frame in both width and height.
- B) Verify the rough opening is plumb, level, and square. (Fig. 4)
- C) Take diagonal measurements to check for square. (Fig. 4)
- D) Make sure the bottom sill area of the opening does not slope toward the interior.
- E) Make sure that the sill area is straight and level over its length. **Sill must be within 1/8" of level for every 10' of sill length.**
- F) Cut the weather-resistant barrier (WRB) in a "Modified I" pattern. (Fig. 5)
- G) Fold back the WRB on the sides and sill toward the interior and staple into place.
- H) From the exterior, cut the top of the WRB to form a flap. (Fig. 5)
- I) Temporarily tape this top flap up. (Fig. 6)

Pockets (for pocket doors only)

- A) The exterior building wall should be finished according to your exposure level to the weather and local building codes.
- B) The pocket cavity should not be sheathed until the frame is installed.
- C) It is recommended that the pocket cavity be painted black.
- D) The post interlock seals the doors to the building and are supplied with the unit. They also require a continuous plane of building material for mounting. (Fig. 4)

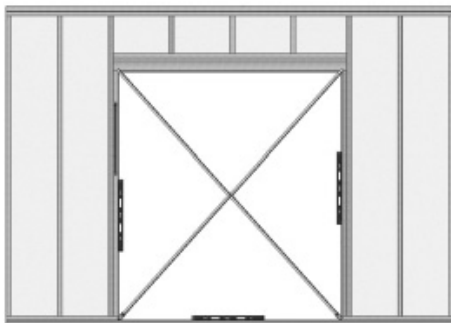

FIG. 4

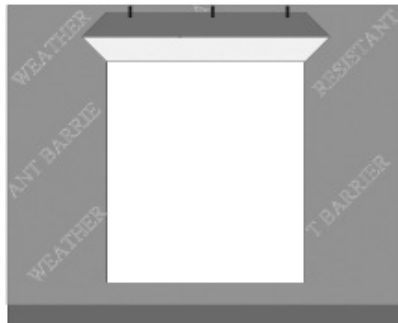

FIG. 5

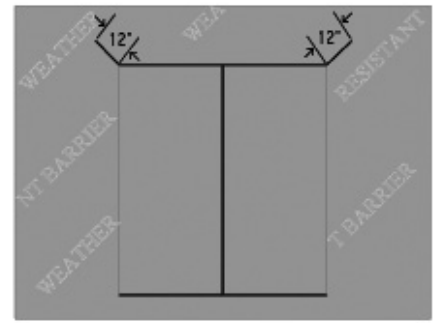

FIG. 6

Flashing Requirements

Follow ASTM E 2112 guidelines for sealing and flashing exterior doors. Maintain a gap at least 1/2" between the door frame and the rough opening structure. Create a proper seal between the door and the building exterior. **A sill pan is REQUIRED.**

Step 3: Sill Pan Flashing

- A) Make sill pan to rough opening dimensions and dry fit it in the opening. The rear leg is required to be a minimum of 3/4" high. (Fig. 7)
- B) Install and attach sill pan to rough opening per ASTM-E 2112 standards, making sure that the sill pan is level once installed.

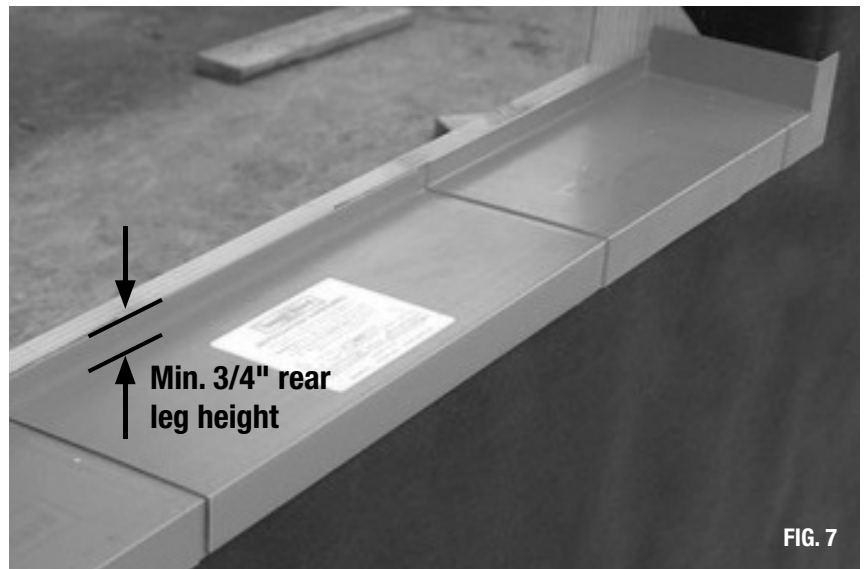

Step 4: Frame Assembly

- A) Install gaskets on the top and bottom of both frame sides and stucco nosing as shown **circled** on Figure 8. For a pocket door, install the post interlock gaskets as well.
- B) Make sure you have a clean flat surface to help protect the frame when assembling. Lay frame head, sill, side jamb(s) and post interlock(s) on the clean flat surface with the exterior side up.
- C) Attach the side jamb(s) to the head using the screws supplied in the "Frame Assembly" screw package. Make sure the screws pass through the side jambs and into the screw bosses in the head **(on the pocket side of a pocketing unit, the base side jamb is not supplied with the exterior nosing; this nosing called the post interlock will be applied in the steps that follow.)** (Fig. 8)

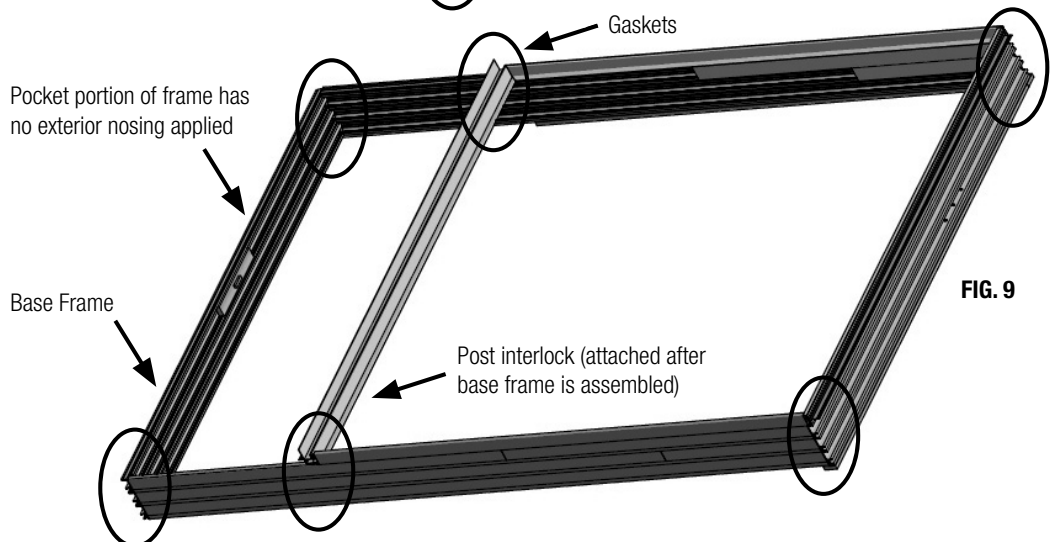
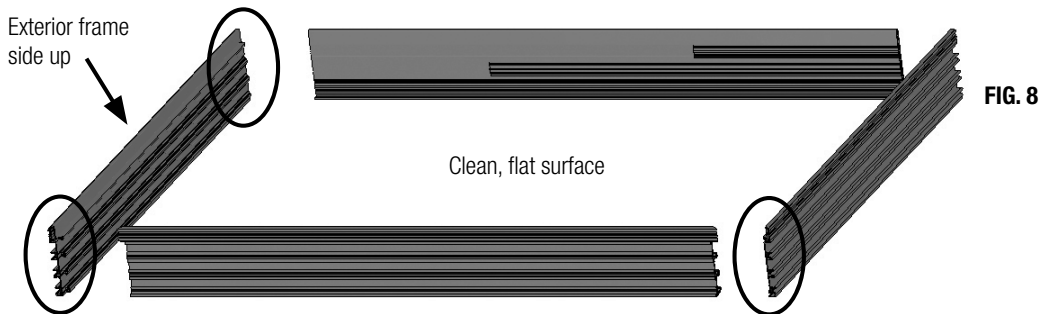

- D) Attach the side jamb(s) to the sill using the screws supplied in the “Frame Assembly” screw package. Make sure the screws pass through the side jambs and into the screw bosses in the sill nosing. (Fig. 8)
- E) Align the pre-drilled hole on the post interlock (Fig. 9) to the holes on the exterior of the pocket side of the frame (the post interlock should line up flush with the frame nosing at the head). Secure the post interlock to the frame sill using the provided screw in the “Post Interlock” screw package. (Fig. 10) **Do not over-tighten screws. Over-tightening the screws will cause the post interlock to collapse at the ends.**

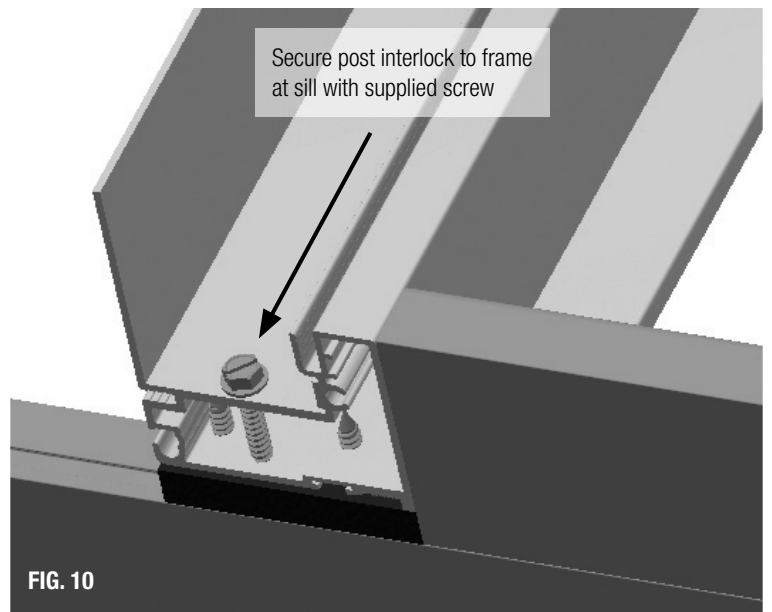

Step 5: Frame Preparation

- A) On each end of the sill, fill the small gap between the sill nosing and the interior wood trim on the interior of the side jamb with sealant. (Fig. 11)

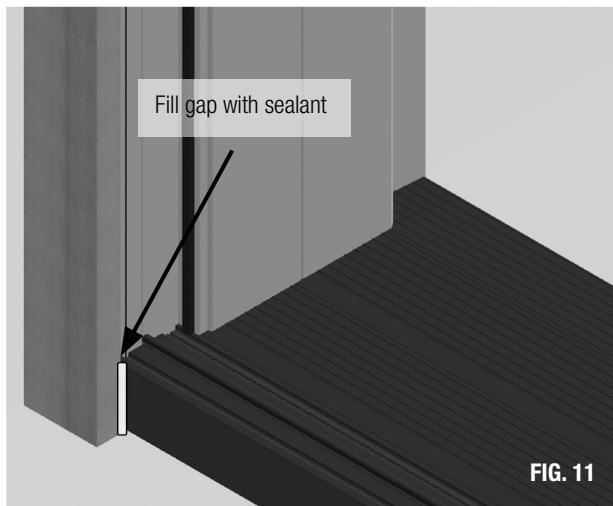

- B) Apply the foam corner seal to the nailing fin on each corner at the head of the unit. (Fig.12)
- C) Run a bead of sealant on the backside of the nail fin on the head and sides as shown in Fig. 12
- D) Apply a 3/16" bead of sealant on the interior upturned leg of the sill pan where the back of the sill will contact the sill pan. (Fig. 13)

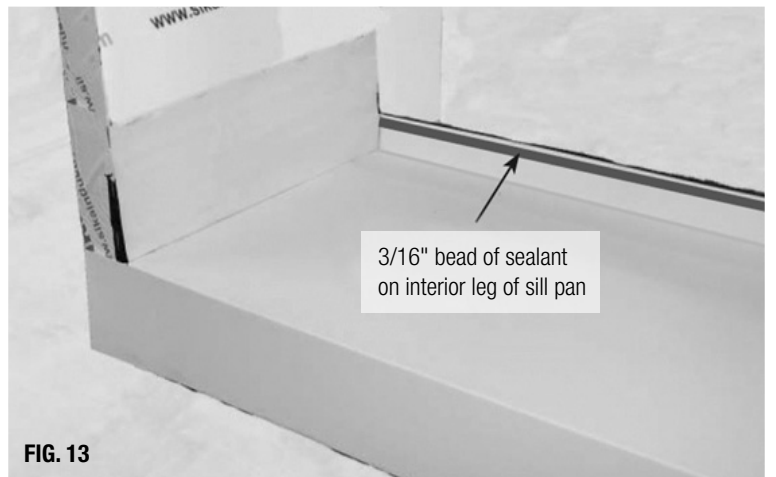

Step 6: Frame Installation

- A) Drill wood sub-floor through the factory pre-drilled holes located in the sill. For masonry application, Tapcon screws are required and are supplied by others. Using a straight edge or level, verify that the sill is level and flat. Use shims as needed to flatten the sill. Apply sealant in each pre-drilled hole in the sill. Attach using fasteners located in the "Sill Install" screw package.
- B) Prior to attaching the head, square the frame to within the allowable tolerances. Using a straight edge and/or level, verify that the top track/head is level and flat. Use shims as needed to level and flatten the head. Attach the head through the pre-drilled holes using the screws located in the "Head Jamb Install" screw package.
- C) Using a straight edge and/or level, verify that the side jambs are level and flat. Use shims as needed to level and flatten the jambs. Attach the side jambs through the factory pre-drilled holes using the screws located in the "Head Jamb install" screw package. There will be two screws with rubber bumpers applied in the accessory kit per jamb cavity that accepts a door in the open position. These screws need to be applied to the top and bottom holes of each cavity.
- D) Cross measure the frame to confirm there is no variance larger than 1/8" per measurement and that the frame is square to within 1/8" horizontally and vertically. (Fig. 14)
- E) Set the frame into the rough opening. Center the frame in the opening, making sure there are equal gaps on both sides of the frame.
- F) Temporarily tack the frame into place using 1-1/2" x #8 coated deck screw on one top corner of the nailing flange.
- G) Check the unit for square using diagonal measurements. Shim frame to ensure the unit is square. Check the unit for square. The difference between the diagonal measurements shall not exceed 3/16". (Fig. 14)
- H) Screw all four corners in place through the nailing flange using 1 1/2" x #8 coated deck screws.
- I) Make sure jambs, head, & sills are straight. Additional shimming will be required.
- J) Shim jambs at each corner. Add additional shims at side jamb no more than 24" apart. See (Fig. 15) for minimum shim placement.

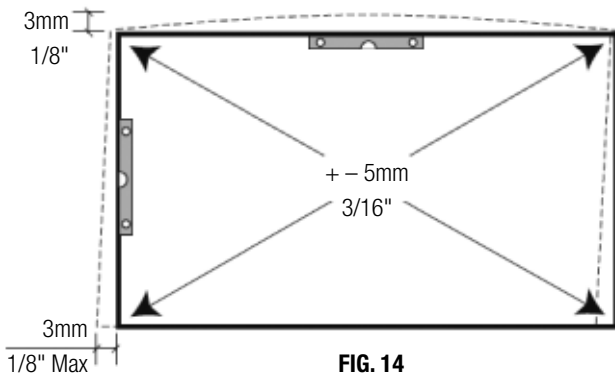

FIG. 14



FIG. 15

Step 7: Panel Installation (installed from the exterior)

- A) All panel types are identified with a sticker (lead, intermediate, stacking or pocket). Install the collector plates on the intermediate panels as shown in Fig. 16.
- B) Beginning with lead panel, holding the panel at an angle toward the head track, insert the top of the panel into the inner most head track and swing the bottom of the panel inward until it is parallel with the top and sits with the wheels on the corresponding sill as shown in Fig. 17.



FIG. 16

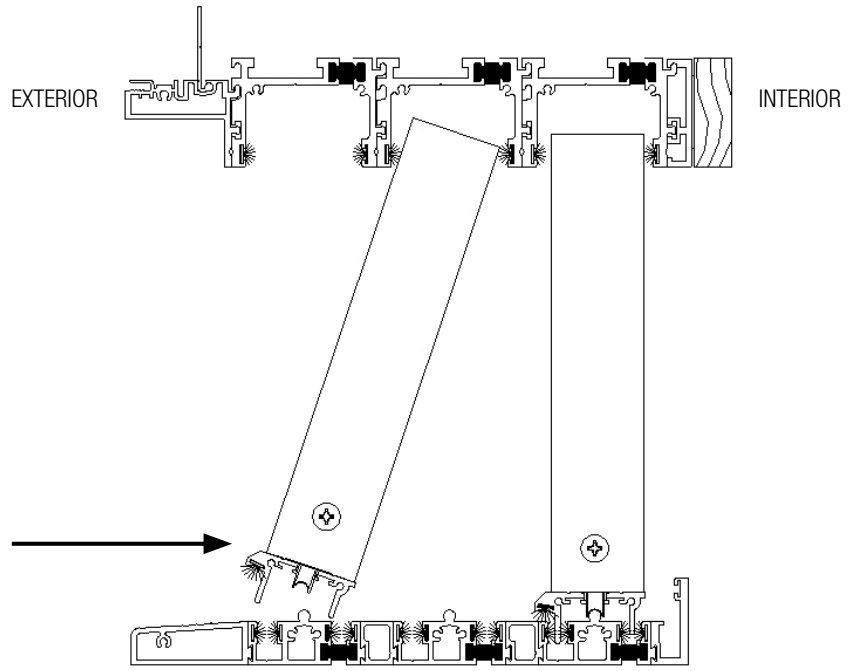

FIG. 17

- C) Maintain space between lead panel and the side jamb to avoid interference with the intermediate panel interlock. Install intermediate panels next. Install pocket or stacking panels last. (Fig. 18)

FIG. 18



Step 8: Follower/Pocket Closure Installation (for pocketing systems only)

- A) Attach the aluminum follower to the back edge of the pocket panel (most exterior panel). Line up the holes/slots in the aluminum follower with the pre-drilled holes in the edge of the panel. Secure the aluminum follower in place by inserting the lag bolt and washer (found in the "follower" screw package) through the hole on the back edge of the aluminum follower and into the pre-drilled holes on the edge of the panel and tightening. **(The washers need to be between the aluminum follower and the head of the bolt. Repeat for each pre-drilled hole.)**
- B) Attach the panel follower trim to the aluminum follower using the supplied screws in the "Interlock" screw package. (Fig. 19)

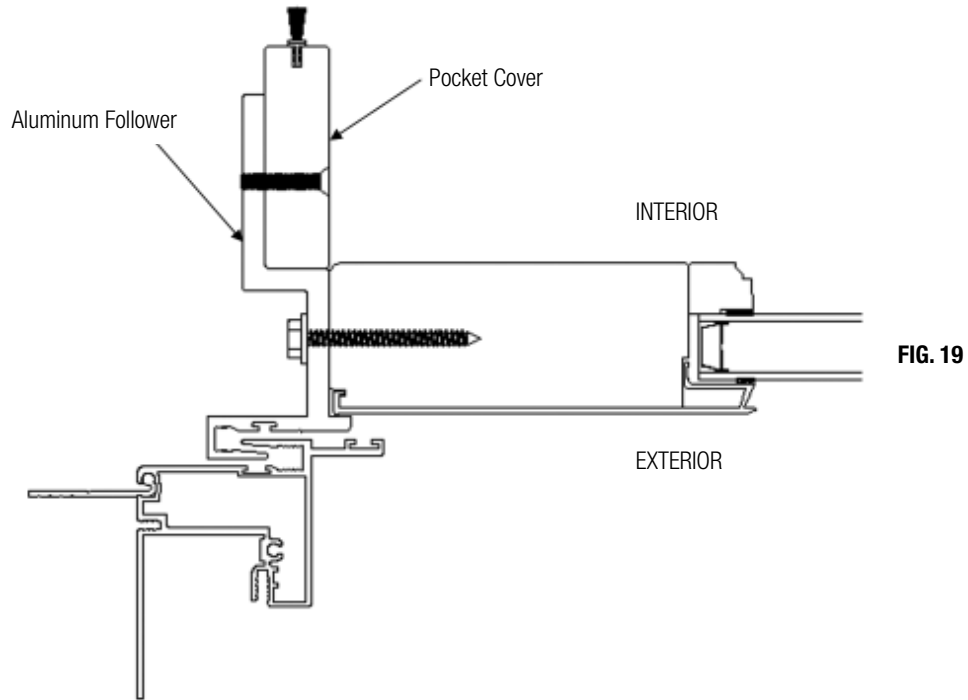

Step 9: Adjustments

- A) Once all panels are installed, close the system and make sure all panel stiles line up properly by adjusting wheels for proper alignment. Wheel adjustments should be used for final tuning only.
- B) Slide the lock side of the active panel within 1/16" from the side jamb interior stop. The gap between the edge of the panel and inside stop must be consistent along the vertical length of the panel. If this is not the case with your unit, you must make adjustments to the rollers. The rollers can be adjusted with a screwdriver on the screws located at the base, on the edges of the panel. Turning the screw in one direction will raise or lower that side of the panel. Make your final adjustments. (Fig. 20) Taking the weight off the rollers will allow for easier adjustment.
- C) Adjust keeper if needed. (Fig. 21)

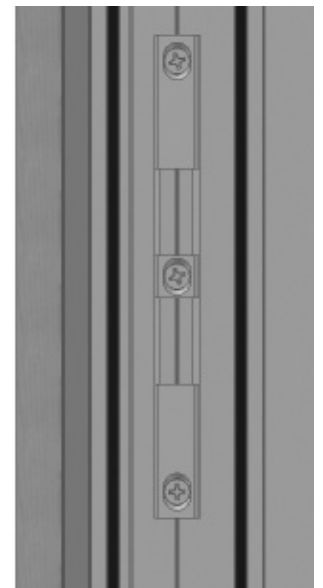
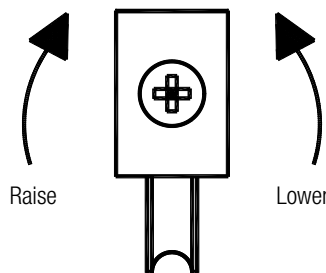

Step 10: Securing Stacking Panel (stacking door only)

- A) Use the included construction handle or a screw driver to lock the stacking panel to the side jamb. This secures and fixes the stacking panel.
- B) Plug access hole with the provided hole cap as shown in Fig. 22.

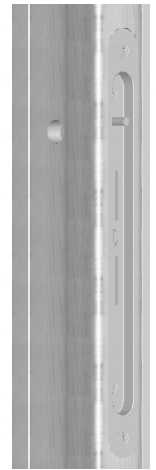

FIG. 22

Step 11: Jamb Cover Installation

- A) Install L-brackets against the pocket/stacking panel and the intermediate panels in the closed position.
- B) Install the head track caps on the exterior facing tracks.
- C) Determine what track each cap goes into based on its overall length before installing.
- D) Make sure the track cap is tight against the side jamb and gently insert it in place. (Fig. 24)
- E) Install the side jamb track caps on the exterior of the locking side jamb by fitting it to the head jamb and gently insert it in place. (Fig. 23)

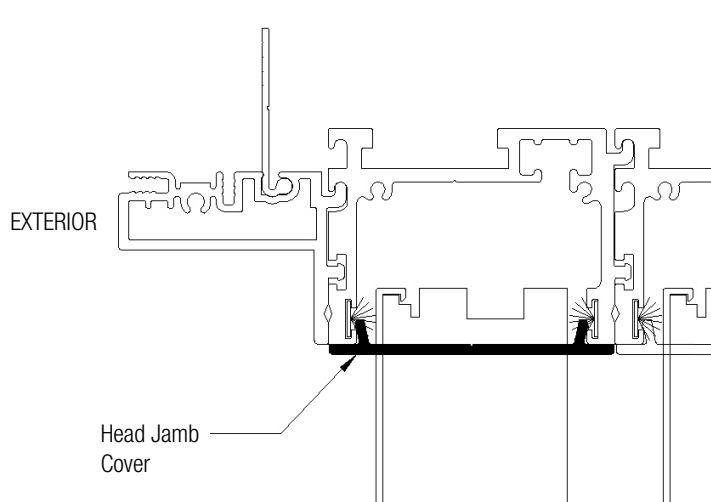
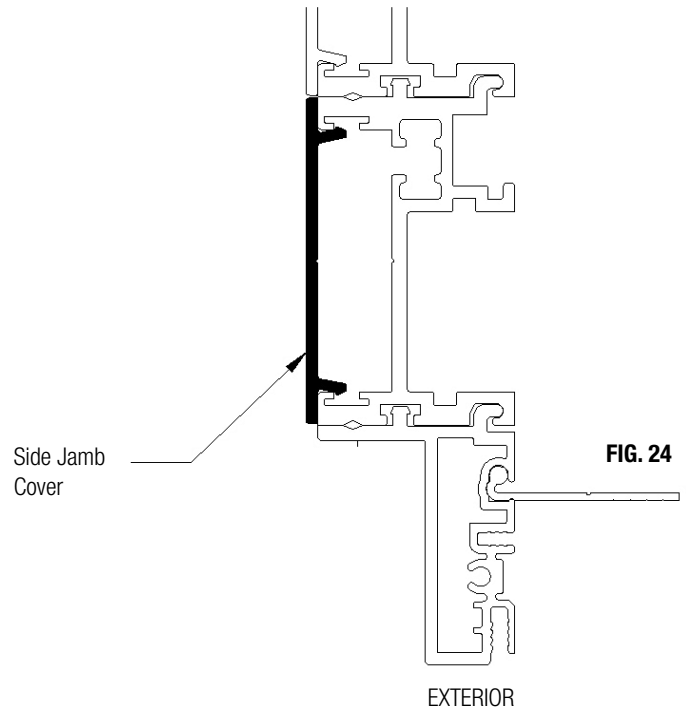

FIG. 23



Step 12: Complete Flashing

- A) Cut and apply side flashing. Side flashing should run from the bottom of the sill flashing to 8" above the rough opening. (Fig. 25)
- B) If non-adhesive flashing is used, make sure all staple holes are sealed with silicone.
- C) Cut and apply head flashing. The head flashing should be on top of the drip cap flashing. The head flashing should run slightly past the edge of the side flashing. (Fig. 26)
- D) Flip down the top flap of the WRB.
- E) Tape the cut seams of the WRB. (Fig. 27)



FIG. 25

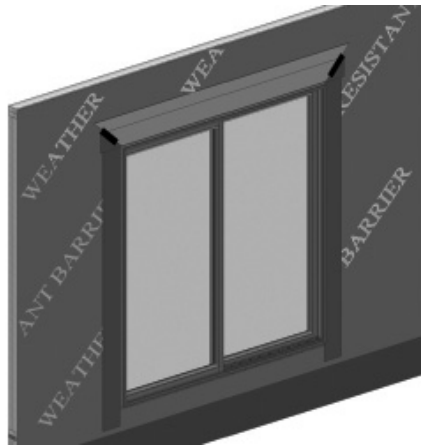

FIG. 26

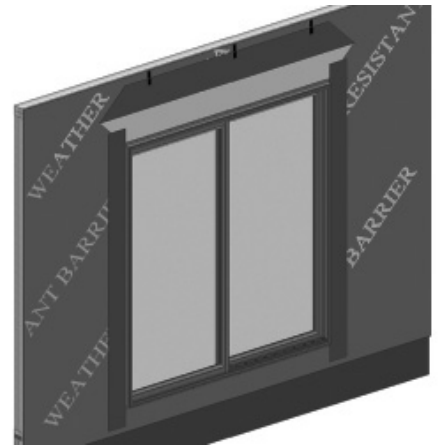

FIG. 27

Step 13: Seal the Exterior

- A) **WARNING:** Maintain a minimum of 1/4" between the window frame and any trim, siding or masonry. Failure to do so will forfeit all warranties (written or implied). Windsor Windows & Doors will not be held responsible for any claims or damages resulting from failure to follow these instructions.
- B) Apply a continuous bead of sealant at the joint between the side jambs and the sill and between the side jambs and the top jamb.

Step 14: Complete the Interior

- A) Remove all labels or shipping materials.
- B) Various hardware adjustments may be required after installation. See the Care and Use Guide located at www.windsorwindows.com for further details.
- C) Insulate between the door frame and the rough opening using minimally expanding window and door spray foam insulation. Use caution to not overfill the gap causing the jambs to bow. It is not recommended to apply trim to the unit until the foam has cured to allow the excess to escape.
- D) Operate door unit to ensure proper operation. The panel will not operate correctly if the door is out of square, over-shimmed or over-insulated.
- E) Properly finish all wood/cellular PVC interior and exterior components within 60 days of installation. See the Care and Use Guide located at www.windsorwindows.com for further details on finishing Pinnacle multi-slide doors.
- F) **IMPORTANT:** Do not stain or paint any hardware or vinyl components.

- G) Apply the handle set as appropriate per the manufacturer's recommendations. Complete final adjustments as necessary.
- H) Sliding doors are to remain closed and locked during construction to prevent site conditions from damaging and/or warping panels and frames. Allow 10-12 weeks from project completion for building temperature and humidity levels to stabilize and door panels to acclimate.

CAUTION! READ BELOW BEFORE PAINTING

When painting cellular PVC products with darker paint colors (L values of 56 or below) UV irradiance can generate high localized temperatures in the product.

WARNING: Painting of any cellular PVC surface with a paint color darker than L value of 56 (where black = 0 and white = 100) will forfeit the product warranty.

If you should, despite the above warning, choose to use darker colors for cellular PVC paint, a paint specifically designed for these applications MUST be used. Contact the paint manufacturer to verify the paints reflective properties and the suitability for painting cellular PVC.

If you have questions regarding the installation or adjustment of your Windsor products, please contact Windsor Windows & Doors directly at 1-800-218-6186. You may also complete and submit the form on the Contact page of our website (www.windsorwindows.com/contact-us) and one of our window specialists will promptly answer your question. On our website, you will also find Care and Use Guides to assist you in preserving your windows and patio doors.

Care and Use

An inspection of your windows should be made annually. Visit the Windsor website (www.windsorwindows.com) or contact your local independent Windsor distributor for information on the care and use of your product. Ask for the Care and Use Guide, which contains information on finishing, cleaning, what to look for during yearly inspections, general maintenance tips, sash/panel adjustment, sash/panel removal, screen removal and information on condensation.

PINNACLE – Limited 20/10 Warranty

Optional Extended-life 30-year Exterior Aluminum Finish Warranty

Windsor Windows & Doors, as manufacturer, warrants from the date of manufacture that all Pinnacle windows and patio doors will be free from defects in materials and workmanship that significantly impair their operation and proper usage, subject to conditions and limitations within. This warranty is transferable to subsequent structure owners, up to the time limits of the warranty. To achieve optimum performance from your Windsor products, and to preserve the warranty, please refer to the Windsor Care and Use Guide on our website, www.windsorwindows.com.

Windsor would like to thank you for selecting our Pinnacle products. We are confident that they will provide you with comfort, aesthetics and value for many years to come. As with any product warranty, there are certain limitations and disclaimers that must be included so that all parties are assured that the product is being installed and used properly. Our intent is to make this warranty as clear and user-friendly as possible.

Pinnacle products carry a “**Limited 20/10 Warranty**,” which provides coverage against insulated glass seal failures for 20 years and coverage for workmanship and materials for 10 years. In addition, we are now introducing optional extended-life exterior aluminum surface finishes that extend the warranty on such finishes to a period of 30 years (see #2 below for details).

There are five primary components to Pinnacle products, and the assurances and warranty provisions are specific to each:

1. Insulated glass used in Pinnacle products:

20 years – Windsor warrants that, from the date of manufacture, and under normal conditions, the insulated glass will not develop any material visual obstructions as a result of premature failure of the insulated glass seal. If a failure of seal occurs, Windsor will provide replacement insulated glass only, for 20 years free of charge. Replacement glass will be shipped F.O.B. factory.

NOTE: There is no coverage for any associated costs, such as installation, disposal or refinishing.

2. Exterior aluminum surface finishes

AAMA 2604: Standard finish – 20-year warranty*

AAMA 2605: Optional upgrade – 30-year warranty*

Anodized: Optional upgrade – 5-year warranty, no warranty for coastal applications*

AAMA 2603: 10-year warranty

- Warranty: Windsor warrants that exterior aluminum surface finishes, when exposed to normal atmospheric conditions, will not peel, check, crack, blister, flake or lose adhesion. This warranty begins on the date of manufacture. Please be aware that exterior aluminum surface finishes will weather and fade over time in any environment. Weathering, chalking and fade will vary depending on conditions, such as exposure to heavy salt spray environments, airborne pollution, elevation, orientation, altitude and other atmospheric conditions. To prolong the life and appearance of the finish coating, it is required that exterior cladding be cleaned and maintained according to a scheduled maintenance

program. If paint failure should occur, Windsor reserves the right to determine the best method for corrective action.

- See Windsor’s website, www.windsorwindows.com, for cleaning and maintenance instructions; also refer to AAMA 610.1-79. Windsor’s website has additional information about each of the available finishes.

*Coastal applications: Applies where units are installed within one mile of the coast. For all finishes except anodized, warranty period is limited to 10 years for these applications.

3. All other parts and components: 10 years (including, but not limited to, such items as weatherstrip and hardware)

– Window and door hardware components are usually manufactured by others and purchased by Windsor for use in our products. Windsor warrants its Pinnacle hardware components, under normal conditions, against premature component failure that substantially impairs the operation or performance of the part or component. In the event of such a failure, Windsor will provide no-charge replacement parts for 10 years from date of manufacture of the Windsor product. Since Windsor purchases many of these parts and components from others, Windsor cannot guarantee that the exact model or design will be available in the future, and usually, the current model will be provided. *NOTE: There is no coverage for any associated costs, such as installation, disposal or refinishing.*

4. Window Sash Opening Limiting Devices

- Always refer to applicable building codes when considering the purchase, installation and application for use as a Window Opening Control Device (WOCD). Also, refer to ASTM F2090-10 for additional information.
- If Window Sash Opening Limiting Devices are going to be installed, carefully follow all information provided with the Window Sash Opening Limiting Devices, including installation, operation and safety information. Proper installation of Window Sash Opening Limiting Devices, pursuant to applicable building codes, ASTM F2090-10, and the included installation information, along with application of tags/labels including the safety instructions left attached for the homeowner, allows these devices to be used as Window Opening Control Devices.
- Supervision is still required around windows where Window Sash Opening Limiting Devices have been installed.
- **Painted White Interior Finish: Two years** – Windsor warrants that under normal conditions, factory-applied interior paint will not peel, check, crack, blister, flake or lose adhesion for a period of two years from date of manufacture. If Windsor determines, subject to the terms and exclusions of this warranty, that a paint failure has occurred, Windsor shall, at its sole discretion, determine the best method for corrective action, which usually includes one of the following: 1) refinish all or a portion of the product; 2) furnish, at no charge, a replacement component part; or 3) refund the original purchase price of the item in question.

(“Interior primed only” products are **excluded** from the interior factory-applied paint warranty.)

The remedies provided in this limited warranty will be forfeited by the occurrence of any of the following conditions:

- Improper installation of the window or door unit. (Installation instructions are factory applied on each unit.)
- Improper installation of multi-slide door unit. Windsor requires an outdoor overhang depth (extended out beyond the face of the door) equal to or greater than the frame height of the multi-slide door. The overhang width must be at least equal to the width of the door.
- Failure to properly finish/protect/maintain windows, doors and their components within 60 days of installation will

forfeit any and all warranties for finishes, as well as warranties applicable to materials and components related to the finish. Failure to properly finish/protect wood components, CPVC components and/or all interior surfaces within 60 days of installation according to finish manufacturers’ recommendations and industry standard finishing methods. Failure to properly maintain any and all finishes, interior or exterior, including finishes applied to components made from CPVC, wood, vinyl or aluminum. (See Windsor’s Care and Use Guide at www.windsorwindows.com.)

- Damage caused by acts of God or some other cause outside Windsor’s control.

WARNING: PAINTING of cellular PVC or any PVC surfaces with a paint not specifically formulated for PVC materials will forfeit the product warranty.

WARNING: PAINTING of cellular PVC or any PVC surfaces with a color darker than L-56 (on the scale where 0=black and 100=white), even with a paint specifically formulated for PVC, will forfeit the product warranty.

- Conditions that exceed the design parameters of the windows.
- Improper removal of any permanent warning or identification labels from the product or products.
- Installation in a non-vertical or sloped application.
- Damage from accident, misuse or abuse.
- Alteration, modification or use for a purpose other than that for which it was intended or designed. (Including, but not limited to, paint applied to vinyl and damage resulting from security systems applied or attached to our product.)
- Application of any tint, UV limiting or sun blocking film to either interior or exterior surfaces of the glass, or the use of film shades.
- Use in or around ships, boats, trailers, campers, swimming pools, hot tubs, spas, saunas or greenhouses.
- Installation exceeding 5,000 feet above sea level, unless high altitude breather tubes have been factory installed.
- Exposure to harmful chemicals.
- Mulling (connecting or attaching) Pinnacle product(s) to those of another manufacturer.
- Failure to follow Windsor’s Care and Use recommendations. (See Windsor’s Care and Use Guide at www.windsorwindows.com.)

- Failure to maintain Painted White Interior Finish. (See Windsor's Care and Use Guide at www.windsorwindows.com.)
- Failure to comply with the claims procedure outlined herein.

Exclusions – The following items or conditions are specifically excluded from the remedies provided by this warranty:

1. Remedies requested for any labor for removal, repair or replacement of defective parts, products or glass, or any repainting or refinishing costs, except as noted above.
2. Remedies requested for any consequential, incidental or punitive damages.
3. Remedies requested for damage caused by or adjustment required from:
 - a. Improper handling, installation or maintenance and/or delivery by others.
 - b. Exposure to conditions beyond performance specifications and/or design limitations.
 - c. Water infiltration other than as a result of a manufacturing defect.
 - d. Condensation and damage caused by the failure to resolve condensation.
 - e. Damage to glass, metal, cellular PVC, PVC or any other surfaces caused by brick wash, sanding, improper cleaning/washing, chemicals or airborne pollutants.
 - f. Minor scratches, and/or minor glass imperfections that do not impede or severely obstruct normal viewing area, and do not impact the structural integrity of the insulated glass.
 - g. Reflective distortion of any kind, including, but not limited to, color, tint, hue or waves inherent to annealed, coated, laminated and tempered glass.
 - h. Heat gain, vinyl distortion or damage of any kind, including, but not limited to, effects due to the reflective properties of glass and its finishes.
 - i. Alignment/location of inner grids of less than or equal to 1/8" from specified location.
 - j. Stresses to product caused by building defects, movement of the building in which the windows are installed, and/or components of that building, including building settlement.
4. Any applicable taxes and freight. (Replacement parts will be shipped to the closest Windsor distributor at Windsor's expense, or the option to ship directly to the homeowner at the homeowner's expense.)
5. Remedies requested for glass breakage, including stress cracks, unless Windsor determines that the breakage or cracking is the result of a manufacturing defect.
6. Remedies requested for special glazing.
7. Laminated and/or impact glass will have a warranty limited to five years against delaminating of inner liner (PVB) and extensive visual obstruction due to glass seal failure.
8. Windsor does not warrant the percentage of inert gas present in high-performance products. Gas dissipates over time at different rates depending upon use and conditions.
9. Remedies requested for inner grid rattle due to lack of uniform supported structure of product, in which the operation of the product or of another product causes vibration harmonics into the Windsor product and induces inner grid to vibrate against the insulated glass, creating a noise.
10. Remedies requested for brass and oil rubbed bronze hardware finishes for finish loss, tarnishing or wear.
11. Remedies requested for corrosion, tarnishing or operation of standard hardware in high salt spray environments.
12. Remedies requested for anodized aluminum exterior finish variances in appearance of color, dielines, pitting and chalking are not warranted.
13. Remedies requested for Painted White Interior Finish failures related to, but not limited to, knots, finger joints, stile and rail separation, joint separation of components, failures resulting from cracking/splitting/raised grain of the substrate, improper installation, lack of maintenance, moisture penetration, condensation or improper cleaning.
14. Remedies requested for fading or chalking exterior aluminum surface finishes are excluded when chalking exceeds number (8) chalk rating using ASTM 4214-98, and fading or color change is greater than 5 delta E in accordance with ASTM D-2244-02.
15. Remedies requested for wood texture, color variations and other wood characteristics within Windsor's specifications.

16. Remedies requested for natural warping of wood components unless the “warp” exceeds 1/4”; warping includes bowing, cupping and twisting.
17. Remedies for swinging doors over seven feet tall, without factory installed multi-point locking hardware, as these products are not warranted against warping or performance.
18. Remedies for any special or custom product or item that is manufactured according to specification provided by the customer.
19. Remedies requested for any product in a size that is greater than that shown in our catalog; these products are purchased “as is” without any warranty.
20. Remedies requested for any product purchased without factory installed glazing; these products are purchased “as is” without any warranty.
21. Remedies requested for any product installed in structures that do not allow for proper management/drainage of moisture, including but not limited to, exterior insulation and finishing systems (EIFS) or “synthetic stucco” without engineered drainage system.
22. Remedies requested for products manufactured by others.

Limits of Liability – Where lawful, this warranty is in lieu of all other warranties, expressed or implied, including any implied warranties of merchantability or fitness for a particular purpose.

- No distributor, dealer, employee, salesperson or representative of Windsor has any authority to change or modify this warranty in any way.
- Windsor is not liable for any consequential, incidental or punitive damages, costs of installation of replacements or costs of refinishing window or door components or adjacent parts/millwork.
- Windsor shall make the final determination as to whether or not a defect exists.
- In addition to, or in lieu of remedies provided herein, Windsor, at its sole discretion, may repair or replace a defective part or product, or refund a portion of the original purchase price.
- Windsor reserves the right to perform warranty work or arrange for another party to perform warranty work.

- In no event shall the liability of Windsor Windows or any seller of Windsor products arising out of a product defect exceed the original purchase price of the product.
- In the event any provision is found to be unenforceable, the remaining provisions shall remain in full force and effect.
- Any component or product repaired or replaced pursuant to this warranty is warranted for the remainder of the original warranty period.
- Affixed to Windsor’s windows are stickers identifying various AAMA and NFRC ratings. These ratings are not performance warranties because window performance will be impacted by conditions and may change over time. These ratings may also apply to single units only, not mulled configurations.
- This is not a warranty of future performance. It is only a warranty to provide the remedies described herein.
- Windsor is not responsible for determining the suitability of its products for particular applications and locations. Nor is Windsor responsible for compliance with building standards, including applicable building codes.
- Windsor makes no warranties whatsoever with respect to accessories or parts not supplied by the manufacturer.
- Windsor may elect to perform repairs in situations where Windsor does not believe any warranty violations exist. This does not constitute a waiver of any of the provisions of this warranty.

Warranty Claim Procedure

If you have any questions regarding this warranty or have a claim under the provisions of this warranty (your "Claim"), please contact your local authorized independent Windsor distributor or one of our manufacturing facilities listed on the back of this brochure. To process a Claim, you must furnish the glass code (numbers and/or letters printed within/upon the insulated glass unit). If you have questions about locating the glass code, please contact one of the Windsor facilities OR REFER TO THE SUPPORT PAGE ON OUR WEBSITE. You must notify your local independent Windsor distributor or Windsor of any defects within a reasonable time, but no later than 30 days after the defect is discovered or reasonably should have been discovered, and within the period covered by the warranty. Windsor may require any defective parts be returned to Windsor or our closest distributor. In order to process a Claim, Windsor reserves the right to inspect the product before it is removed or modified in any way. Windsor field visits may result in service charges if a non-warranty site survey is required and/or requested.

Response by Windsor

Windsor will have 30 days to respond to your Claim, with an explanation of what Windsor is willing to do relative to your Claim. Please keep in mind that this response may include an explanation of some action Windsor would like to take, such as conducting further investigation, or it may state that Windsor is not willing to take any action. We point this out to make it clear that Windsor is committing to respond to your Claim, not agreeing to remedy the problems described in every Claim it receives. If you are in any way dissatisfied with Windsor's response to your Claim, you must follow the steps of Windsor's Dispute Resolution Process as outlined below.

Dispute Resolution Process

You and Windsor agree that any dispute arising out of or related to the Windsor products shall be settled pursuant to the terms of the Dispute Resolution Process defined in this warranty. The term Dispute shall include any claims related to the terms of this warranty, including claims related to the enforceability of any of its terms, and including claims alleging breach of this or any other warranty. The term Dispute shall also include claims alleging breach of contract, breach of warranty, tortious conduct on the part of Windsor, including, but not limited to, negligence, violation of state or federal laws, ordinances or regulations, and product liability claims, claims of fraud, misrepresentation and violation of any consumer protection statute or laws.

Notice of Dispute

The first step in the Dispute Resolution Process is for you and Windsor to attempt to resolve your Dispute informally. The first step is for you to provide Windsor with a Notice of Dispute. This can be found by going to www.windsorwindows.com/support, which will take you to a form that you need to fill out.

Response by Windsor

Windsor will have 60 days to respond to your Notice of Dispute by providing a written explanation of what Windsor is willing to do relative to your Dispute.

Waivers of Jury Trial and No Class Actions

IF YOU AND WINDSOR ARE UNABLE TO RESOLVE YOUR DISPUTE TO YOUR SATISFACTION, YOU CAN THEN SEEK TO FORMALLY RESOLVE YOUR DISPUTE BY RESORTING TO THE COURT SYSTEM. HOWEVER, YOU AGREE THAT

YOU CAN ONLY DO SO AS AN INDIVIDUAL AND IN YOUR INDIVIDUAL CAPACITY, AND NOT AS A CLASS MEMBER OR REPRESENTATIVE IN A CLASS OR OTHER REPRESENTATIVE ACTION OR PROCEEDING. YOU ALSO AGREE THAT YOU CANNOT HAVE YOUR DISPUTE RESOLVED BY A JURY TRIAL, AND HEREBY WAIVE ANY RIGHT YOU MAY HAVE TO A JURY TRIAL, AND INSTEAD YOU AGREE THAT YOUR CASE WILL BE TRIED BY A JUDGE.

Waiver Opt-Out Option

As stated above, YOU CAN OPT OUT OF THE ABOVE WAIVERS. To do so, please to go www.windsorwindows.com/support and locate the Waiver Opt-Out Form. In order to opt out of these provisions, you must fill out the Waiver Opt-Out Form within one year of the date your Windsor products were manufactured, as indicated by the glass code on the product.

Failure to Follow Procedures or Processes

The failure to follow any of the steps outlined in the Claims Procedures or Dispute Resolution Process sections of this document does not alter, waive or void any of the terms of this document. The only way to alter, waive or void any of these terms is by "Opt Out" as described herein.

Applicable Law and Severability

This Dispute Resolution Process, including, but not limited to, issues related to its enforceability and effect, will be governed by the laws of the State of Minnesota without regard to conflict of law principles. If any term of this Dispute Resolution Process is found to be invalid or unenforceable in any particular jurisdiction, that term will not apply to that issue in that jurisdiction. Instead, that term will be severed with the remaining terms continuing in full force and effect.

Effective on Pinnacle products manufactured after 2/1/2016.