

PINNACLE SELECT LIFT & SLIDE (Wood Interior)

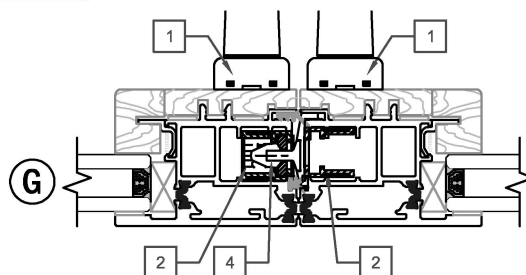

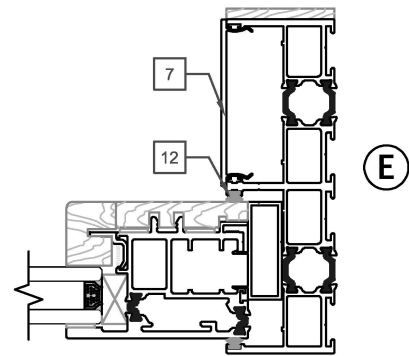

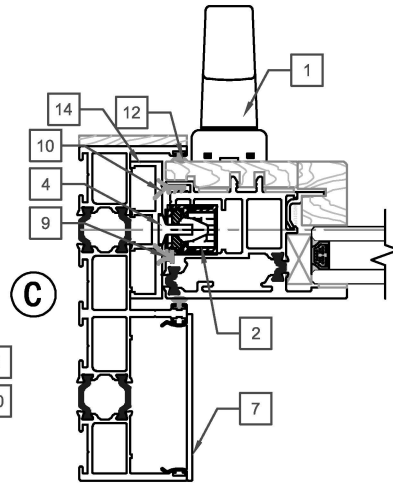

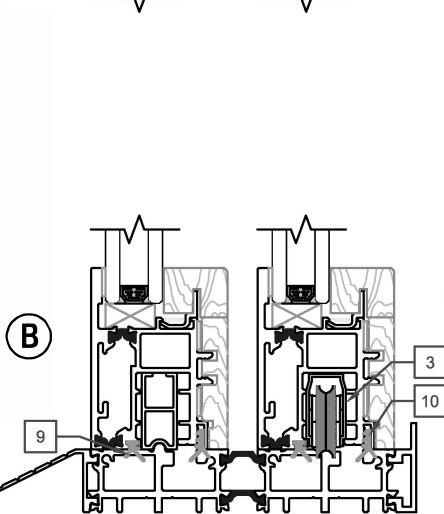
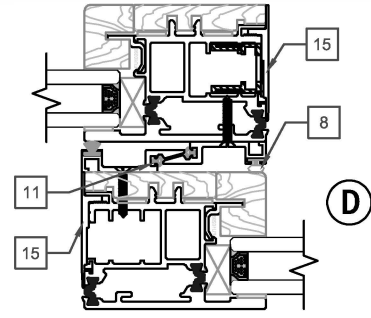
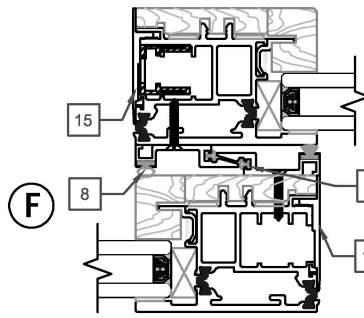
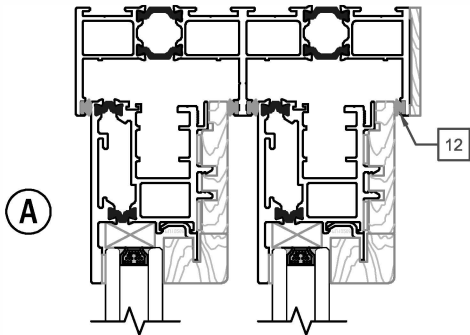
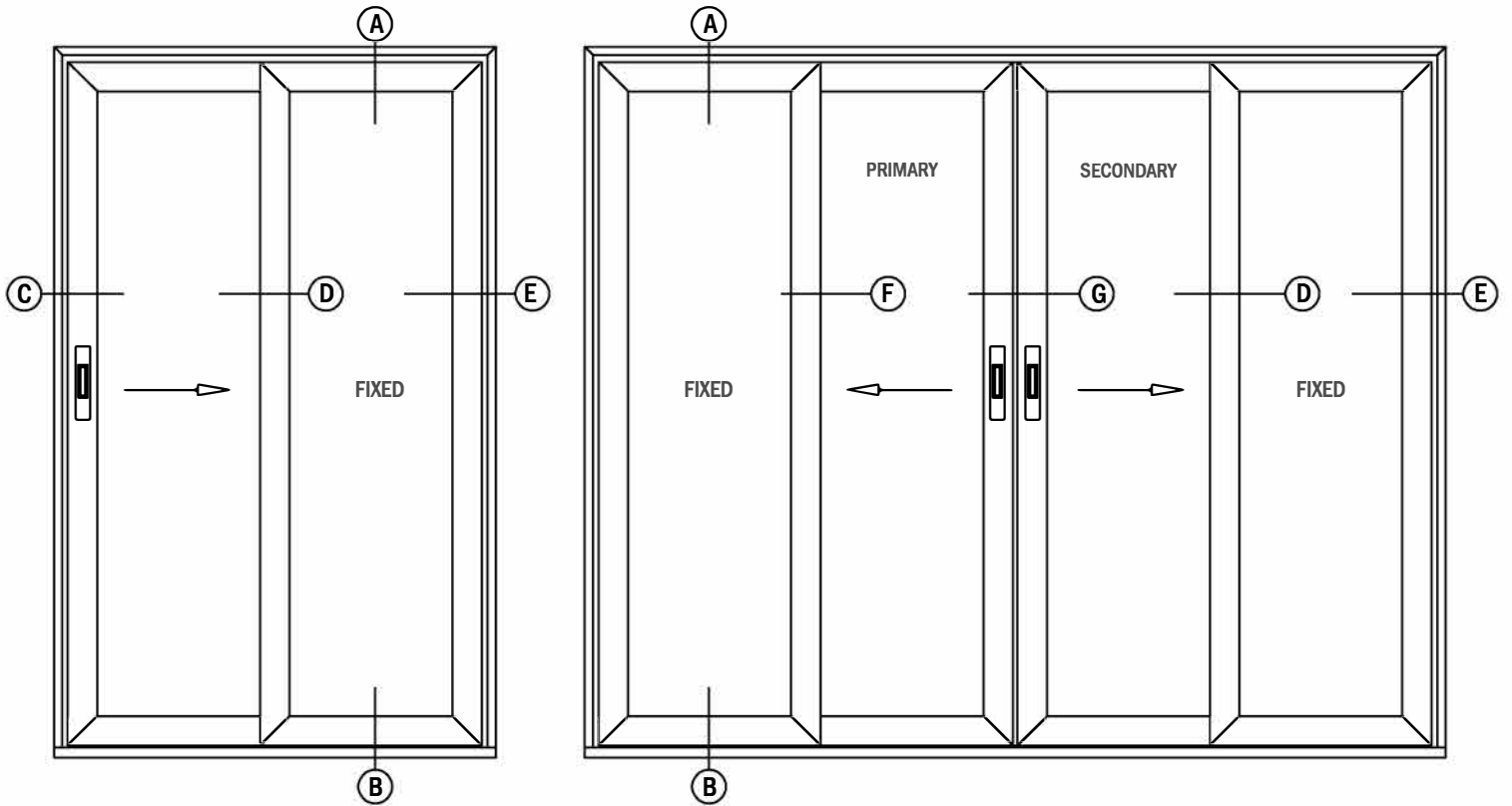



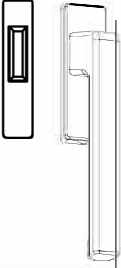

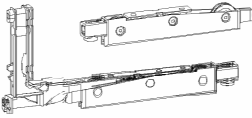
11-22 - 1

PART LIST







PINNACLE SELECT LIFT & SLIDE (Wood Interior)

11-22 - 2

IMAGE	ITEM #	DESCRIPTION	TYPE	PART #
	1	Q-ARTE (PRIMARY/SECONDARY PANEL)	DARK BRONZE SATIN CHROME	48093 48094
	2	OPERABLE PANEL MECHANISM WILL NEED PANEL SIZE	PRIMARY NON-PRIMARY PRIMARY (coastal) NON-PRIMARY(coastal)	48095 48096 48108 48109
	3	L&S WHEEL SET WILL NEED PANEL SIZE	GRAY WHITE (coastal)	48097 48110
	4	L&S POINT LOCKS	GRAY	48098
	5	INTERLOCK TOP CAP/ BOTTOM CAP RIGHT STACK (EXT.VIEW) LEFT STACK (EXT.VIEW)	BLACK	48057
	6	INTERLOCK TOP CAP/ BOTTOM CAP LEFT STACK (EXT.VIEW) RIGH STACK (EXT.VIEW)	BLACK	48059
	7	SIDE FRAME/HEADER CAP	PC TO MATCH	48060
	8	INTERLOCK BUBBLE GASKET	GRAY	48099
	9	PANEL RAIL GASKET EXTERIOR SIDE	BLACK	48100
	10	PANEL RAIL GASKET INTERIOR SIDE	BLACK	48101
	11	INTERLOCK GASKET	BLACK	48061
	12	SMALL BASE FELT BRUSH SIDE FRAME ONLY	BLACK	48064
	13	LARGE BASE FELT BRUSH INTERLOCK, BI-PART,BOTTOM RAIL	BLACK	48065

PINNACLE SELECT LIFT & SLIDE (Wood Interior)

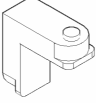
11-22 - 3

IMAGE	ITEM #	DESCRIPTION	TYPE	PART #
	14	L&S SIDE FRAME ASTRAGAL	PC TO MATCH	48102
	15	PANEL COVER LOCATED IN INTERLOCK SIDE	PC TO MATCH	48103
	16	ADJUSTABLE KEY CORNER SIDE FRAME/HEADER KEY CORNER	GRAY	48104
	17	REMOVABLE HANDLE NON-PRIMARY PANEL HANDLE	PC WHITE PC BLACK PC SILVER	48105 48106 48107